

UDC 620.197: 630.841.2/841.4/842.3/845.54: 674.04

## WOOD MODIFICATION RESEARCH AT THE UNIVERSITY OF SOPRON

R. Németh, M. Bak, J. Ábrahám, F. Fodor, N. Horváth, M. Báder

*University of Sopron*

*Bajcsy-Zsilinszky str., 4, Sopron, 9400 Hungary*

E-mail: nemeth.robert@uni-sopron.hu, bak.miklos@uni-sopron.hu, abraham.jozsef@uni-sopron.hu, fodor.fanni@phd.uni-sopron.hu, horvath.norbert@uni-sopron.hu, bader.matyas@uni-sopron.hu

*Received 28.01.2019*

This overview presents the research fields of the Institute of Wood Science at the University of Sopron (Hungary) in the first two decades of the third millennium. The classic wood research topics such as physical, mechanical and anatomical examinations of untreated wood species are one of the major fields of the studies conducted. The other major part is the topic of this paper, i.e. the study of different wood modification processes. There are many possibilities in wood science to improve the properties of wood and, as a result, to improve its usability. Various heat treatments were performed in gaseous atmosphere for more than ten softwood and hardwood species, as well as heat treatment in different fluids. The latter includes the treatment in vegetable oils, paraffin and beeswax to improve the resistance and dimensional stability of wood. Within the mechanical wood modification the densification of poplar resulted in a great increase of its hardness to make this common wood available in more fields of wood industry. The longitudinal compression of hardwoods results in obtaining a flexible material that extends the usability of wood. As a chemical treatment, acetylation provides a good protection against wood-destroying organisms, a high increase in dimensional stability and a long life span. The impregnation of wood with different nanoparticles has successfully improved its durability. In summary, this paper demonstrates several processes from mechanical wood modifications through heat treatments to chemical modification methods.

**Keywords:** *acetylation, beeswax, densification, heat treatment, impregnation, longitudinal wood compression, nanomaterials, oil, paraffin, pleating.*

**How to cite:** *Németh R., Bak M., Ábrahám J., Fodor F., Horváth N., Báder M.* Wood modification research at the University of Sopron // *Sibirskij Lesnoj Zurnal* (Sib. J. For. Sci.). 2019. N. 3: 20–25 (in English with Russian abstract).

DOI: 10.15372/SJFS20190303

### INTRODUCTION

Wood is recognised as the most important of the renewable base materials with the added advantage of being recyclable and CO<sub>2</sub>-neutral. But wood is a biodegradable material. Many traditional protection treatments currently exist to prevent these deteriorations and they are based mostly on toxic materials. The aim is to get better performance of the wood, resulting in improvements in dimensional stability, decay resistance, weathering resistance, etc. Wood modification by different techniques dates back to decades at the University of Sopron (Simonyi Károly Faculty of Engineering, Wood Sciences and

Applied Arts, Institute of Wood Science). Besides the basic studies, for example the study of physical and mechanical properties of different wood species (Dömény et al., 2015; Komán and Fehér, 2015; Németh et al., 2016; Komán, 2018; Vörös and Németh, 2018 etc.), special attention was given to heat treatment processes in different media, acetylation, some impregnation processes and application of nanoscale materials in wood industry as well as compression of wood perpendicular and parallel to grain. Wood modification processes indicate continuously new challenges. The main investigation topics of the Institute of Wood Science at the University of Sopron are described below.

## HEAT TREATMENT IN GASEOUS ATMOSPHERES

The institute possesses a programmable heat treatment chamber that can handle samples of up to 60 cm in length. This electrically heated, fan-ventilated equipment carries out the treatments in normal atmospheric-pressure air, without added gases or steam (dry heat treatment). As a result, the resistance to fungal decay improves remarkably and swelling decreases, while exotic and more homogeneous colour can be achieved in the whole cross-section of the wood (Horváth and Csupor, 2012). In addition to useful properties, both compression strength and hardness slightly increase, mostly in case of treatments carried out at 200 °C (Horváth et al., 2012). These properties are very useful for producing floor elements made of dry heat-treated hardwood (Fig. 1).

However, bending strength and tensile strength as well as impact bending strength decrease considerably, by 20–40 and by 30–70 %, respectively. In 2010, a combined heat treatment-steaming equipment with 0.5 m<sup>3</sup> capacity was purchased. This autoclave is suitable for heat treatments up to 250 °C in vacuum, inert gases and steam. The wood species investigated by our institute so far are oak, turkey oak, black locust, poplar, hornbeam, beech, maple, pine, spruce, tree-of-heaven and acacia.

## HEAT TREATMENT IN DIFFERENT FLUIDS

The efficiency of the heat treatment processes depends on the rate and regularity of heat growth in the wood and on reducing oxidative processes in order to avoid unnecessary decomposition. Heat treatment in vegetable oils can be a solution to these problems. Wood was heat treated at 160–200 °C in rapeseed-, linseed- and sunflower oil (Fig. 2).

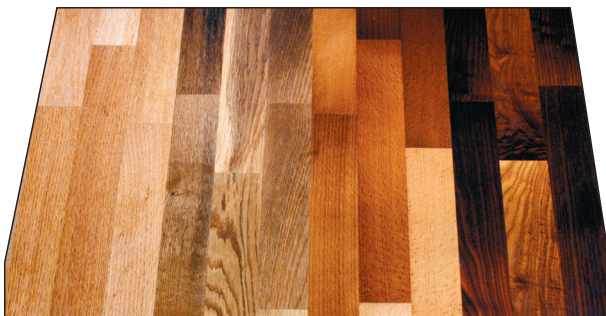

**Fig. 1.** Flooring elements made of dry heat-treated turkey oak, oak, beech and ash (left to right) (Németh et al., 2012b).

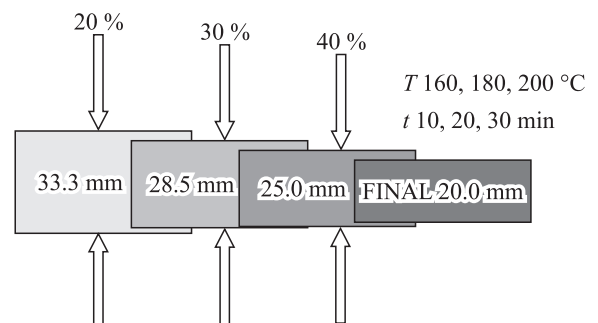

**Fig. 2.** Colour change of poplar wood due to different heat treatment schedules in linseed oil (Németh et al., 2012b).

Swelling properties decreased by 20–60 % and strength decreased less than by heat treatment in a gaseous atmosphere. Colour changes were similar to the heat treatments in gaseous atmosphere. Further advantage of heat treatment in vegetable oils is the short treatment time (in case of a 25 mm thick poplar board, up to 6 hours including drying). It must be noted that for example in case of black locust, which has a practically impermeable structure, longer treatment times are needed to avoid cracks and deformations (Bak and Németh, 2012). Using paraffin as a heat treatment medium instead of vegetable oils, similar results can be achieved, and moisture absorption is further reduced by a thin paraffin layer on the surface (Németh et al., 2012a).

## COMPRESSION PERPENDICULAR TO THE GRAIN (DENSIFICATION)

In case of a product, often only one property is important to meet the requirements. Indoors, surface hardness of poplar wood is the property that limits its use. In this case, the aim was to produce a low-density material with high surface hardness. Using thermo-hygro-mechanical treatment, applying heat, steam and compression on wood – the hardness of the poplar can be increased from very low 10 to 22 N/mm<sup>2</sup> (Fig. 3).



**Fig. 3.** Parameters of the different THM process schedules (Németh et al., 2016).

30 % compression of the poplar increases the hardness by 120 % and reaches the hardness of maple wood, which is a popular wood species in flooring element production. Besides the improved surface hardness, the wood will have a brownish colour at a depth of 2–3 mm (Ábrahám et al., 2010).

### COMPRESSION PARALLEL TO THE GRAIN

Longitudinal wood compression and relaxation after compression (fixation means that the sample is held compressed for a while) is called pleating and result in improved bending properties, compared to the classical steaming wood bending process. The method can be used mostly for high density hardwoods. Another advantage is that longitudinally compressed wood can be kept cold for longer time in bendable state, therefore it is storable. This material can be used primarily in interior design and in the furniture industry. During the modification process, the normally smooth cell walls deform, buckle and finally seem like a plisse form. The term «pleating» originated from this phenomenon (Báder and Németh, 2018a) (Fig. 4).

Pleating as well as bending requires high-quality hardwood raw material with high density. Before the compression procedure the wood must be plasticized, practically by steaming. The compression ratio is 15–25 % of the original length. Fixation also increases the bendability of the wood. After longitudinal compression and fixation, the shortening of the samples increases.

### ACETYLATION OF WOOD

Acetylation changes hydroxyl groups in wood to acetyl-groups. In a preliminary study (Gohér, 2009), the swelling of poplar wood (*Populus* × *euramericana* cv. Pannonia) decreased by 70 %,

beside that the mechanical properties remained unchanged. Black locust *Robinia pseudoacacia* L. could not be effectively treated. However, for veneer or flake, good results were achieved (e. g. production of weather resistant panels). As a next step hornbeam *Carpinus betulus* L. wood was acetylated (Fodor, 2015; Fodor et al., 2017) at Accsys Technologies (the Netherlands). The results are promising, as the equilibrium moisture content and fibre saturation point decreased by 58 and 33 % respectively. Shrinkage decreased by ~80 % in radial and tangential directions, and by ~60 % in longitudinal direction. Weight loss due to fungi decay decreased by 95–98 %. Acetylated wood has pungent smell for a long time caused by evaporation of acetic acid; also the increased corrosion caused by the application of hinges is to be taken into account. Acetylation produces a slight effect on wood colour. Light coloured woods become slightly darker, while dark coloured woods slightly lighter (Fig. 5).

### OTHER WOOD MODIFICATION PROCESSES

In addition to the modification processes discussed above, some other processes were also investigated. First of all, impregnation processes with beeswax or nanoparticles should be mentioned. Both treatments significantly improve the decay-resistance and the dimensional stability. Zinc nanoparticles improved the durability of wood very effectively due to the application of very low agent concentrations. Even better results could be achieved by using zinc-borate compared to zinc oxide (Lykidis et al., 2016). Impregnation by beeswax decreases the moisture uptake of wood significantly (10–40 %) and it increases the durability in short-term applications, thus wood can be treated with natural-based preservatives for wood without any chemicals (Németh et al., 2015) (Fig. 6).

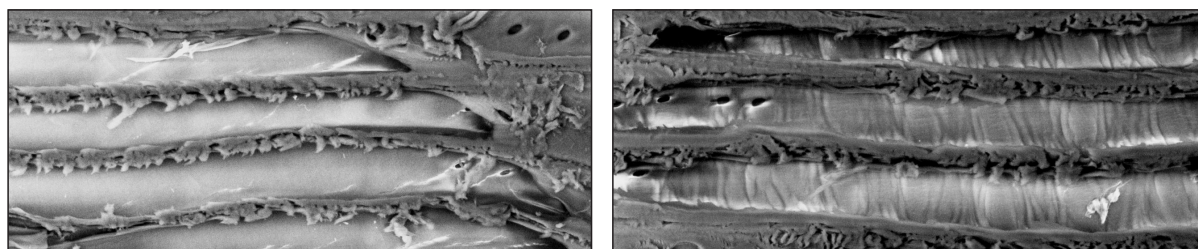

Fig. 4. SEM images of oak wood: before (left) and after (right) the longitudinal compression and fixation treatments (magnification 1000 x) (Báder and Németh, 2018b).



Fig. 5. Colour change as a result of acetylation on hornbeam wood (left untreated; right treated) (Fodor, 2015).

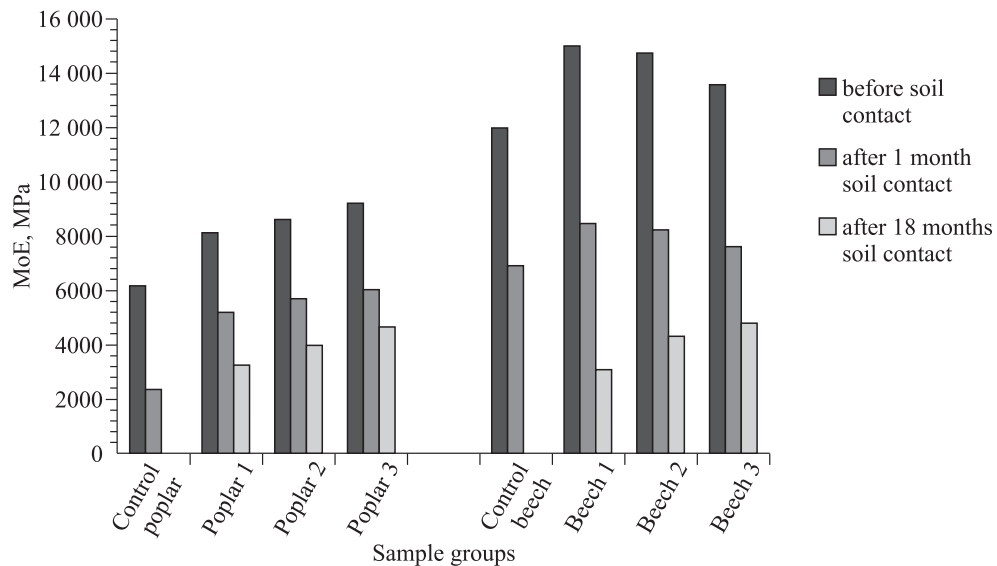

Fig. 6. MoE of poplar and beech samples impregnated with beeswax (untreated and 3 different degrees of pore saturation: 1 – low; 2 – medium; 3 – high level of pore saturation) in different investigation periods (Németh et al., 2015).

## CONCLUSIONS

During the last 20 years at the University of Sopron (Institute of Wood Science) important research activities have been carried out in relation to different wood modification processes. In the course of these investigations the effects of numerous wood modification processes were studied. The main topics were the study of different heat treatments (heat treatment in different gaseous atmospheres or liquids besides high pressure or atmospheric pressure), but also the investigation of acetylation and environmentally friendly

wood preservatives (beeswax, nano-zinc particles, etc.). The mechanical wood modification processes (densification and longitudinal compression) were also studied and the physical and mechanical properties of different wood species as basic research.

*The project was carried out as a part of the «Production with nature – Agroforestry as a new perspective», EFOP-3.6.2-16-2017-00018 project in the framework of the Széchenyi 2020 Program. The project has been supported by the European Union, co-financed by the European Social Fund.*

## REFERENCES

- Ábrahám J., Németh R., Molnár S. Thermo-mechanical densification of Pannonia Poplar // Proc. of the final Conf. of COST Action E53: Quality control for wood & wood products, 4–7<sup>th</sup> May 2010, Edinburgh, UK. Edinburgh: For. Prod. Res. Inst. / Centre for Timber Engineer., Edinburgh Napier Univ., 2010. P. 282–292.
- Báder M., Németh R. The effect of the relaxation time on the mechanical properties of the longitudinally compressed wood // Wood Research. 2018a. V. 63. N. 3. P. 383–398.
- Báder M., Németh R. The effect of the rate of longitudinal compression on selected wood properties // Acta Silv. Lign. Hung. 2018b. V. 14. N. 1. P. 83–92.
- Bak M., Németh R. Changes in swelling properties and moisture uptake rate of oil-heat-treated poplar (*Populus × euramericana* cv. Pannónia) wood // Bioresources. 2012. V. 7. N. 4. P. 5128–5137.
- Dömény J., Čermák P., Pařil P., Fodor F. F., Dejmál A., Rademacher P. Application of microwave heating for acetylation of beech (*Fagus sylvatica* L.) and poplar (*Populus hybrids*) wood // Bioresources. 2015. V. 10. N. 4. P. 8181–8193.
- Fodor F. Gyertyán faanyag (*Carpinus betulus* L.) modifikálása acetilezéssel (Modification of hornbeam *Carpinus betulus* L. wood by acetylation). MSc thesis. Sopron, Hungary: Univ. Sopron, 2015. 79 p. (in Hungarian).
- Fodor F., Lankveld C., Németh R. Testing common hornbeam (*Carpinus betulus* L.) acetylated with the Accoya method under industrial conditions // Forest-Biogeosciences and Forestry. 2017. V. 10. Iss. 6. P. 948–954.
- Gohér G. Nyár acetilezése (Summer acetylation). MSc thesis. Sopron, Hungary: Univ. West Hungary, 2009. 60 p. (in Hungarian).
- Horváth N., Csupor K. The protective effectiveness of dry heat treatment on Turkey oak against fungal decay // Proc. 5<sup>th</sup> Conf. Hardwood Res. and Utilisation in Europe 2012: Hardwood Science and Technology / R. Németh, and A. Teischinger (Eds.). Sopron (HU): Nyugat-magyarországi Egyetem, 2012b. P. 135–143.
- Horváth N., Csupor K., Molnár S., Németh R. The effect of dry thermal treatment on wood properties with special emphasis on wood resistance to fungal decay // Proc. Int. Sci. Conf. Sustainable Development and Ecological Footprint / M. Neményi, and B. Heil (Eds.). Sopron (HU): Nyugat-magyarországi Egyetem, 2012. P. 1–6.
- Komán Sz. Energy-related characteristics of poplars and black locust // BioResources. 2018. V. 13. N. 2. P. 4323–4331.
- Komán Sz., Fehér S. Basic density of hardwoods depending on age and site // Wood Res. 2015. V. 60. N. 6. P. 907–912.
- Lykidis C., Bak M., Mantanis G., Németh R. Biological resistance of pine wood treated with nano-sized zinc oxide and zinc borate against brown-rot fungi // Europ. J. Wood & Wood Products. 2016. V. 74. Iss. 6. P. 909–911.
- Németh R., Bak M., Csordós D. Thermische modifizierung von Buche und Pappel mittels paraffin // Holztechnologie. 2012a. N. 53. Iss. 6. P. 5–10.
- Németh R., Bak M., Horváth N. Wood modification at the University of West Hungary // Proc. 5<sup>th</sup> Conf. Hardwood Res. and Utilisation in Europe 2012: Hardwood Science and Technology / R. Németh, and A. Teischinger (Eds.). Sopron (HU): Nyugat-magyarországi Egyetem, 2012b. P. 135–143.
- Németh R., Bak M., Horváth N., Ábrahám J., Fodor F., Csupor K., Csóka L. Wood modification related research at the University of West Hungary // World Conf. Timber Engineer / F. Alireza (Ed.). Wien, Austria, 2016. P. 6228–6236.
- Németh R., Tsalagkas D., Bak M. Effect of soil contact on the modulus of elasticity of beeswax-impregnated wood // Bioresources. 2015. V. 10. N. 1. P. 1574–1586.
- Vörös Á., Németh R. The historical development of wood hardness tests part 2 – Static indentation methods 1915–1950 // Gradus. 2018. V. 5. N. 2. P. 178–187.

УДК 620.197: 630.841.2/841.4/842.3/845.54: 674.04

## ИССЛЕДОВАНИЯ МОДИФИКАЦИИ ДРЕВЕСИНЫ В ШОПРОНСКОМ УНИВЕРСИТЕТЕ

**Р. Немет, М. Бак, Дж. Абрахам, Ф. Фодор, Н. Хорват, М. Бадер**

*Шопронский университет*

*Венгрия, 9400, Шопрон, ул. Бази-Жилински, 4*

---

E-mail: nemeth.robert@uni-sopron.hu, bak.miklos@uni-sopron.hu, abraham.jozsef@uni-sopron.hu,  
fodor.fanni@phd.uni-sopron.hu, horvath.norbert@uni-sopron.hu, bader.matyas@uni-sopron.hu

*Поступила в редакцию 28.01.2019 г.*

Представлены исследования Института древесиноведения Шопронского университета (Венгрия) в первые два десятилетия третьего тысячелетия. Это в основном классические исследования физических, механических и анатомических свойств необработанных древесных пород. Другой важной частью исследований является изучение различных процессов модификации древесины. В древесиноведении известно много способов улучшения свойств древесины и, как следствие, – улучшения ее использования. Проведена различная термическая обработка более десяти видов мягкой и твердой древесины в газовой атмосфере, а также в различных жидкостях. Последнее включает обработку растительными маслами, парафином и пчелиным воском для улучшения стойкости и стабильности размеров древесины. В рамках механической модификации древесины тополя уплотнение привело к значительному увеличению ее твердости, что сделало эту распространенную породу доступной во многих областях деревообрабатывающей промышленности. Продольное сжатие древесины лиственных пород позволяет получать гибкий материал, который расширяет возможности ее использования. Химическая обработка, ацелирование обеспечивают очень длительный срок защиты против разрушающих древесину организмов и значительное повышение стабильности ее размеров. Пропитка древесины различными наночастицами повышает ее долговечность. В статье рассматриваются различные процессы механической модификации древесины с помощью термообработки и методов химической модификации.

**Ключевые слова:** *ацелирование, пчелиный воск, уплотнение, термообработка, пропитывание, продольное сжатие древесины, наноматериалы, масло, парафин, складывание.*